



# SCHIRTEC®

## SCHIRTEC LIGHTNING CONDUCTORS INSTALLATION CHART\*



\* This is only our recommendation, but you can use any other installation charts which are suitable to your national standard.

- 1- SCHIRTEC E.S.E. Lightning Conductors (Schirtec AS, Schirtec A, Schirtec DAS, Schirtec DA)
- 2- SCHIRTEC LC Tester (SA-1T)
- 3- Joint Adaptor
- 4- Wall Clamps
- 5- Galvanized Mast
- 6- Plastic Holders for isolated floors / roofs
- 7- Plastic Holders for isolated walls

- 8- Wall Holders
- 9- Down Conductors
- 10- SCHIRTEC Lightning Strike Counter (SLSC-10)
- 11- Test Clamps
- 12- Protection Pipe
- 13- Earthing Rod Coupling
- 14- Inspection Pits
- 15- Earthing Rod

**THE DETAILS OF EXTERNAL LIGHTNING PROTECTION SYSTEM**

**Ⓢ E.S.E. Lightning Conductor Head**

Early Streamer Emission Lightning Conductor for large area protection.

**Ⓢ Lightning Conductor Mast**

The E.S.E. Lightning Conductor height may be increased by means of an elevation mast. We recommend, Lightning Conductor Mast should be galvanized steel, is to be min. 3 m in length and 60 mm in diameter, down conductors must be fixed with 1 meter max. distance between the conductor spread along the vertical plane.

**Ⓢ Down and Grounding Conductors**

**Number of Down - Conductors**

Each E.S.E. Lightning Conductor should be connected to the earth termination system by at least one down conductor. Two or more down-conductors are required when:

- The horizontal projection of the conductor is larger than its vertical projection.
- External Lightning Protection is installed on any structures higher than 28m.

The down-conductors should be installed on two different main walls.

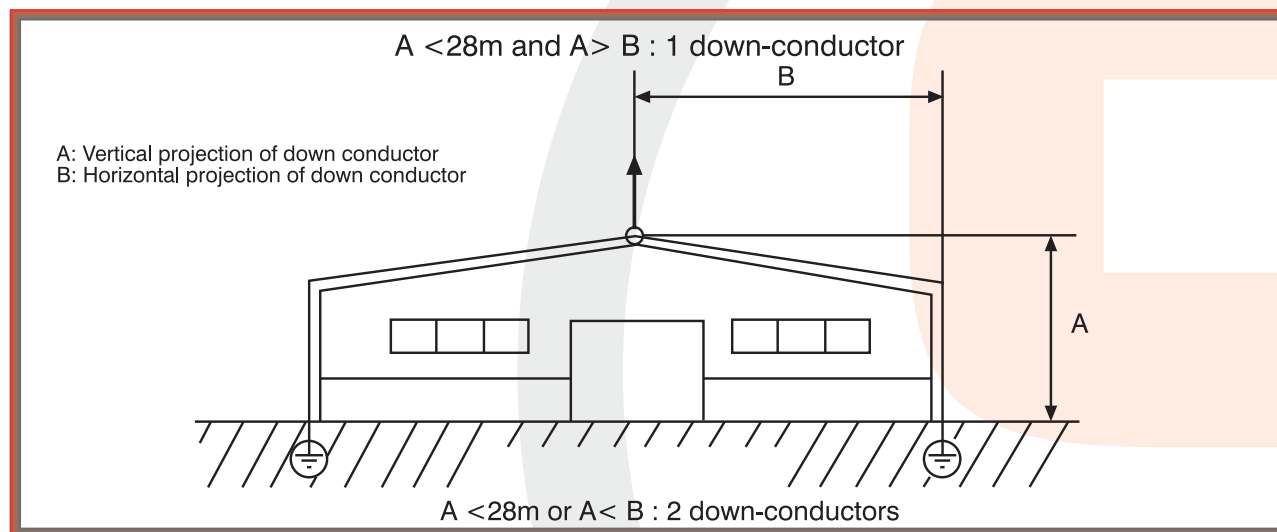

(Figure 1) - Number of down-conductors

Down-conductors consist of strips, braided cables, or round sections. Their minimum cross-sectional area of 50 mm<sup>2</sup> is defined in below table.

Down-conductors		
Material	Remarks	Minimum dimensions
Bare or tin-plated electrolytic copper (1)	Recommended for its good conductivity and corrosion resistance	Strip: 30x2 mm Round section: 8 mm dia.(2) Braided cable: 30x3,5 mm
18/10-304 stainless steel	Recommended in certain corrosive environments.	Strip : 30x2 mm Round section: 8 mm dia.(2)
A 5/L aluminium	To be used on aluminium surfaces (cladding, curtain- walls)	Strip : 30x3 mm Round section : 10 mm dia.(2)

(1) Tin-plated copper is recommended in view of its physical, mechanical and electrical properties ( conductivity, malleability, corrosion resistance, etc.)

(2) As the lightning current has an impulse characteristic, the flat conductor is preferred to the round conductor since its outside surface area is larger for a given cross-sectional area.

It must be a fixed mounting surface with conductor fixing internal distance is 1 mt. It should be installed in such a way that its path is as direct as possible. It should be as straight as possible along the shortest path without sharp bends or upward sections. As seen figure, It is connected d/L. (Figure 2)

Where; d: safety distance, L: the length of conductor according to shock voltages the average max. value, approximately is not be a jumping danger for  $L < 20 d$ .

The down conductors should not be routed along or across electrical conduits. However, when electrical conduit crossing is unavoidable, the electrical conduit should be placed inside a metal screen which extends 1 m beyond the point of crossing. The screen should be connected to the down conductor.

Routing round parapet walls should be avoided. Provisions should be made to ensure that down conductors paths are as direct as possible.

However, a maximum height increase of 40 cm is permissible for passing over a parapet wall with a slope of 45° or less. (Figure 2)

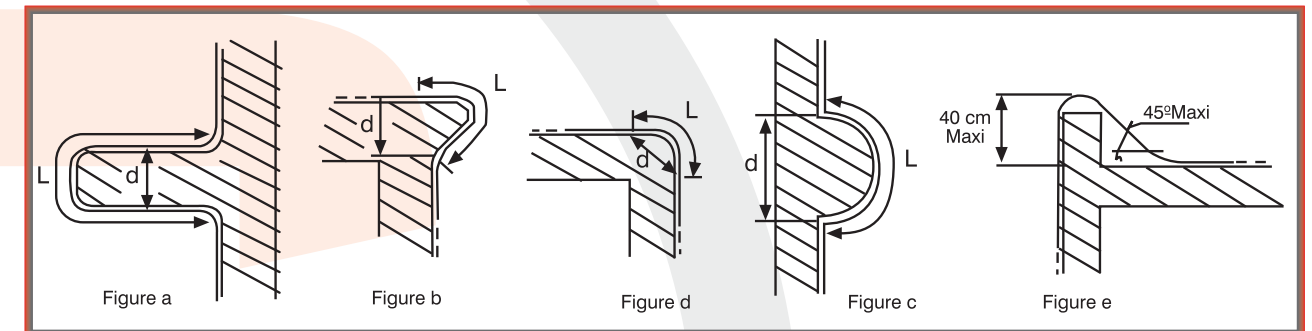

(Figure 2)

**Ⓢ Protective Cover**

It protects the down-conductors against mechanical damages. You can use U profile or pipe. To prevent the lightning charge down, conductors must be connected to pipe or to U profile.

**Ⓢ Lightning Strike Counter**

When a lightning strike counter is used to match the number of lightning stroke it should be installed on the most direct down conductor above the test clamp and in any case at height of about 2m. above the ground level.

**Ⓢ Test Clamp**

According to down conductor, covered plastic, is provided to measure the earth resistance, in an accessible position on each main earthing conductor between earthing electrode and must be over protective tube.

**Ⓢ Earth Termination**

You should use reliable earth electrodes according to IEC 62305-3. They shall be extensible and driven as deep as possible in earth starting from a minimum depth of 50 cm in the earth and located at such distance from one and other that maximum current likely to flow through one as they do not significantly effect the potential of the other's (5 m). Earth Resistance is less than 10 Ohm.

**Ⓢ Mounting**

It must be checked after corrosion between different materials and avoided using different materials as much as possible. The wall's surface must not be destroyed to fixing the carrier pole, conductor clips. It must be provided both canal digs for grounding system and ground on which a building must be rebuilt for grounding system.

**Ⓢ Project**

It must be projected to mounting in truth.

**Ⓢ Test Report**

After the installation is finished, earth resistance must be measured by the authorized personel and than it must be reported and approved by an authorized engineer.

Hướng dẫn lắp đặt Kim thu sét S-AM, S-AS, S-DAS, S-A, S-DA

# SOME EXAMPLE OF OUR INSTALLATIONS



# SOME EXAMPLE OF OUR INSTALLATIONS



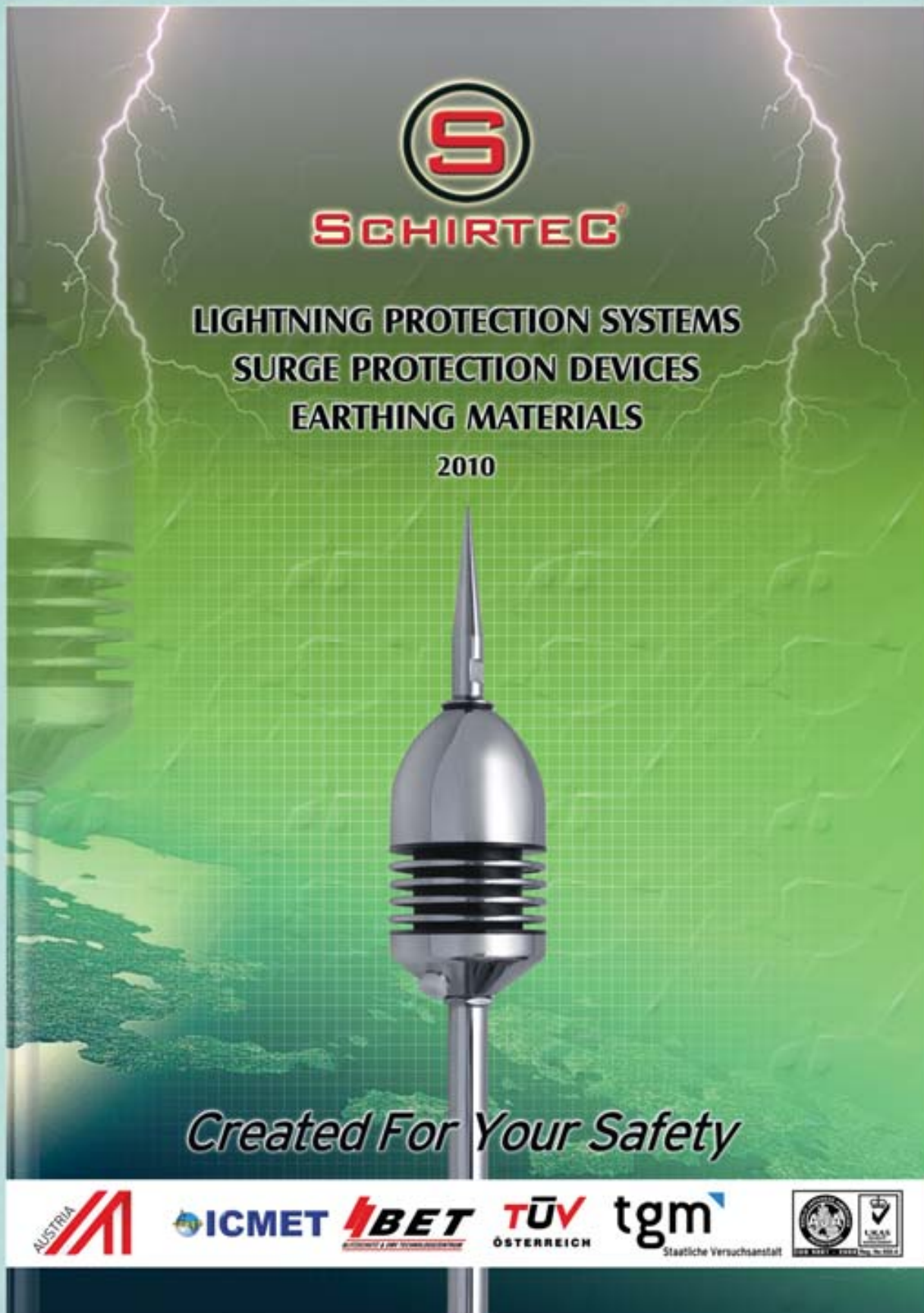

The cover features a central image of a lightning rod against a green background with a grid pattern and lightning bolts. The Schirtec logo, a red 'S' in a black circle, is at the top. Below it, the text 'SCHIRTEC' is written in a red, stylized font. Underneath, the product categories 'LIGHTNING PROTECTION SYSTEMS', 'SURGE PROTECTION DEVICES', and 'EARTHING MATERIALS' are listed in black. The year '2010' is centered below these. At the bottom of the cover, the slogan 'Created For Your Safety' is written in a white, italicized font. A white banner at the very bottom contains several logos: 'AUSTRIA' with a red 'M' logo, 'ICMET', 'BET', 'TUV ÖSTERREICH', 'tgm' with 'Staatliche Versuchsanstalt' below it, and two circular certification logos.

**SCHIRTEC**  
LIGHTNING PROTECTION SYSTEMS  
SURGE PROTECTION DEVICES  
EARTHING MATERIALS  
2010

*Created For Your Safety*

AUSTRIA **M** ICMET **BET** TUV ÖSTERREICH **tgm** Staatliche Versuchsanstalt

**SCHIRTEC AG**

IGNAZ-KÖCK STRASSE 10  
1210 WIEN / AUSTRIA

PHONE: +43 1 27574 1601 +43 1 27574 1602  
FAX: +43 1 27574 1610

[www.schirtec.at](http://www.schirtec.at) e-mail: [info@schirtec.at](mailto:info@schirtec.at)

**Authorized Distributor**

**Công Ty TNHH Lê Khang Corp**

- Tel: 0869 278 279  
- Email: [info@LeKhangCorp.com](mailto:info@LeKhangCorp.com)  
- [LeKhangCorp.com](http://LeKhangCorp.com) - <http://chongset.com>